

Bi2[®]
 THE COOLING
 RADIATOR

THE FAN-RADIATOR

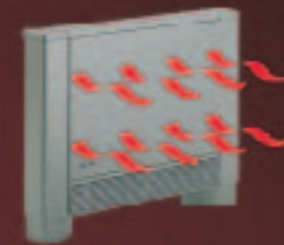

**OLIMPIA
 SPLENDID**
 NEW USER FRIENDLY SYSTEMS

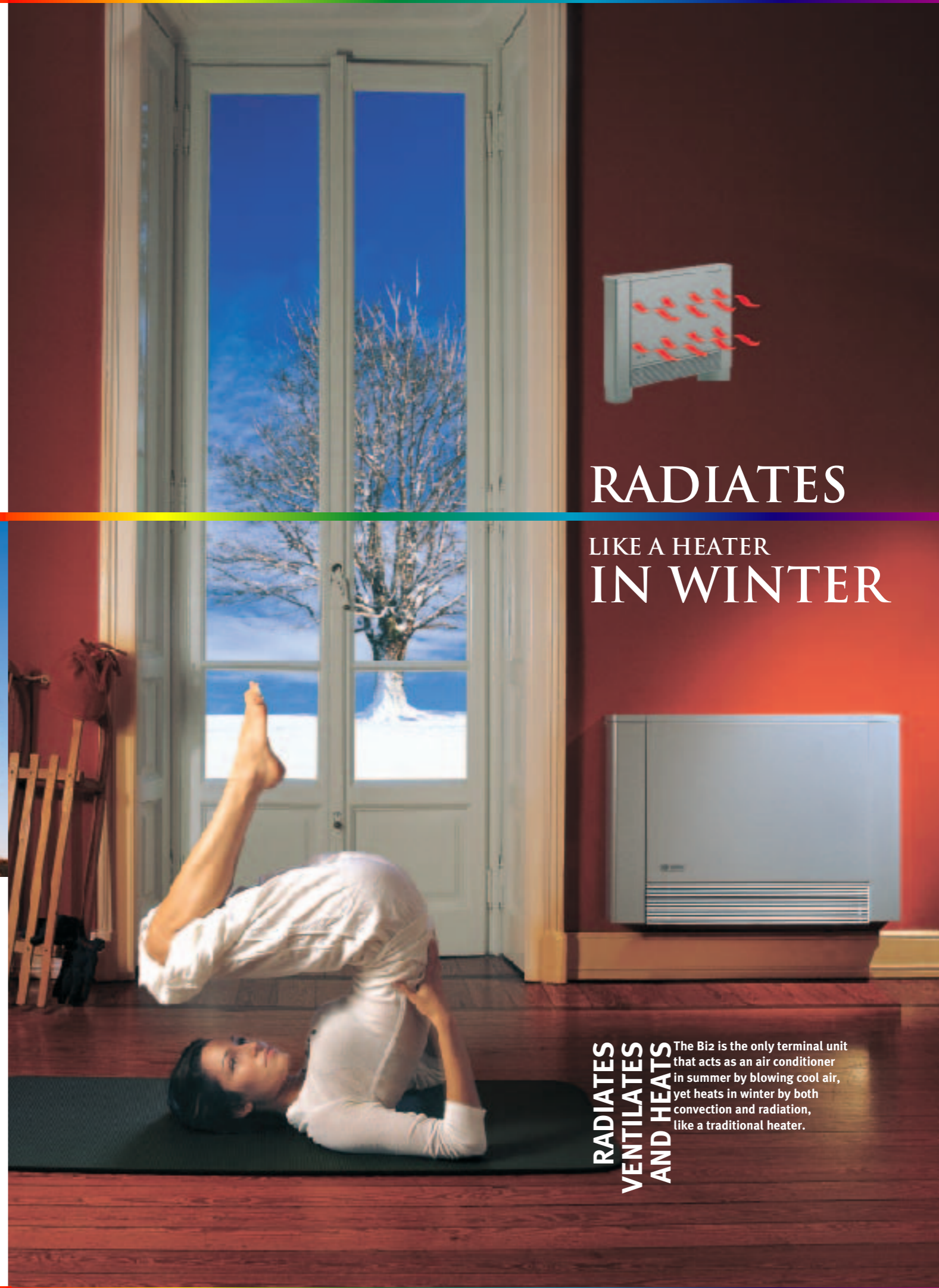

RADIATES

LIKE A HEATER
 IN WINTER

**RADIATES
 VENTILATES
 AND HEATS** The Bi2 is the only terminal unit that acts as an air conditioner in summer by blowing cool air, yet heats in winter by both convection and radiation, like a traditional heater.



VENTILATES

LIKE AN AIR CONDITIONER IN SUMMER



In summer, the Biz cools and dehumidifies like the most efficient air conditioner. It can be installed anywhere in the building like a normal heater.

SLR VERSION (WITH RADIATOR PLATE)

MODEL		SLR200	SLR400	SLR600	SLR800	SLR1000
Silver		code 00607	code 00611	code 00615	code 00619	code 00623
White (RAL 9010)		code 00606	code 00610	code 00614	code 00618	code 00622
(a) Total cooling capacity	W	880	1750	2350	2900	3900
Sensible cooling capacity	W	700	1470	1920	2400	3190
Water flow rate	l/h	151	301	404	499	671
Water pressure drops	kPa	5	10	20	20	26
(b) Heating capacity (water 50°C)	W	1350	2500	3000	4400	5409
Water flow rate (50°C)	l/h	215	390	519	701	890
Water pressure drops (50°C)	kPa	5	10	20	18	26
(c) Heating capacity (water 70°C)	W	2500	4100	6100	7200	10000
Water flow rate (70°C)	l/h	215	353	525	619	860
Water pressure drops (70°C)	kPa	5	8	18	16	25
Max. static heating capacity (70°C)	W	652	785	961	1203	1470
Coil water content	dm ³	0,4	0,8	1,1	1,4	1,8
Radiator plate water content	dm ³	0,9	1,3	1,7	2,1	2,4
Maximum operating pressure	bar	10	10	10	10	10
Water pipe fittings	inches	Eurokonus 3/4	Eurokonus 3/4	Eurokonus 3/4	Eurokonus 3/4	Eurokonus 3/4
(d) Max. air flow rate	m ³ /h	177	355	534	712	891
Min. air flow rate	m ³ /h	69	142	214	287	360
Supply voltage	V/ph/Hz	230/1/50	230/1/50	230/1/50	230/1/50	230/1/50
Max. current absorption	A	0,25	0,25	0,29	0,29	0,54
Max. power absorption	W	50	50	60	60	110
(e) Sound power at max. air flow rate	dB(A)	38	41	44	47	49
Sound power at min. air flow rate (min. night speed)	dB(A)	28	30	32	33	35
Sound pressure at max. air flow rate	dB(A)	31	34	38	40	42
Sound pressure at min. air flow rate	dB(A)	21	23	25	26	28
Total length	mm	697	897	1097	1297	1497
Total height (without feet)	mm	645	645	645	645	645
Total depth	mm	128	128	128	128	128
Net weight	Kg	24	30	36	42	48

SL VERSION (WITHOUT RADIATOR PLATE) AND SLI VERSION (BUILT-IN WITHOUT RADIATOR PLATE)

MODEL		SL200	SLI200	SL400	SLI400	SL600	SLI600	SL800	SLI800	SL1000	SLI1000
Flush-fitting											
Silver		code 00605	code 00624	code 00609	code 00625	code 00613	code 00626	code 00617	code 00627	code 00621	code 00628
White (RAL 9010)		code 00604		code 00608		code 00612		code 00616		code 00620	
(a) Total cooling capacity	W	880	880	1750	1750	2350	2350	2900	2900	3900	3900
Sensible cooling capacity	W	700	700	1470	1470	1920	1920	2400	2400	3190	3190
Water flow rate	l/h	151	151	301	301	404	404	499	499	671	671
Water pressure drops	kPa	5	5	10	10	20	20	20	20	26	26
(b) Heating capacity (water 50°C)	W	1210	1210	2300	2300	2700	2700	3950	3950	4800	4800
Water flow rate (50°C)	l/h	151	151	301	301	404	404	499	499	671	671
Water pressure drops (50°C)	kPa	5	5	9	9	19	19	19	19	25	25
(c) Heating capacity (water 70°C)	W	2350	2350	3900	3900	5700	5700	6600	6600	9300	9300
Water flow rate (70°C)	l/h	202	202	335	335	490	490	568	568	800	800
Water pressure drops (70°C)	kPa	10	10	12	12	22	22	22	22	28	28
Coil water content	dm ³	0,4	0,4	0,8	0,8	1,1	1,1	1,4	1,4	1,8	1,8
Maximum operating pressure	bar	10	10	10	10	10	10	10	10	10	10
Water pipe fittings	inches	Eurokonus 3/4	Eurokonus 3/4	Eurokonus 3/4	Eurokonus 3/4	Eurokonus 3/4	Eurokonus 3/4	Eurokonus 3/4	Eurokonus 3/4	Eurokonus 3/4	Eurokonus 3/4
(d) Max. air flow rate	m ³ /h	177	177	355	355	534	534	712	712	891	891
Min. air flow rate	m ³ /h	69	69	142	142	214	214	287	287	360	360
Supply voltage	V/ph/Hz	230/1/50	230/1/50	230/1/50	230/1/50	230/1/50	230/1/50	230/1/50	230/1/50	230/1/50	230/1/50
Max. current absorption	A	0,25	0,25	0,25	0,25	0,29	0,29	0,29	0,29	0,54	0,54
Max. power absorption	W	50	50	50	50	60	60	60	60	110	110
(e) Sound power at max. air flow rate	dB(A)	38	38	41	41	44	44	47	47	49	49
Sound power at min. air flow rate (min. night speed)	dB(A)	28	28	30	30	32	32	33	33	35	35
Sound pressure at max. air flow rate	dB(A)	31	31	34	34	38	38	40	40	42	42
Sound pressure at min. air flow rate	dB(A)	21	21	23	23	25	25	26	26	28	28
Total length	mm	697	479	897	679	1097	879	1297	1079	1497	1279
Total height (without feet)	mm	585	576	585	576	585	576	585	557	585	576
Total depth	mm	128	126	128	126	128	126	128	126	128	126
Net weight	Kg	19	18	23	22	27	26	31	30	35	34

Notes:

- (a) Water temperature at coil inlet 7° C, Water temperature at coil outlet 12° C, Room temperature 27° C db and 19° C wb
- (b) Water temperature at coil inlet 50° C, water flow rate as for cooling + plate, ambient air temperature at inlet 20° C.
- (c) Water temperature at coil inlet 70° C, water temperature at coil outlet 60° C, ambient air temperature at inlet 20° C.
- (d) Sound power measured as per ISO23741/2 Standards.

OLIMPIA SPLENDID SpA
via Guido Rossa, 1-3
42044 Gualtieri (RE) Italy
tel +39 0522 22601
fax +39 0522 828745

www.olimpiasplesndid.com
export@olimpiasplesndid.it

Notes

Product appearance and technical specification are subject to change. Olimpia Splendid reserves the right to make any changes without giving prior notice.



The Bi2 is patented.
International patent
N° PCT/IT03/00512

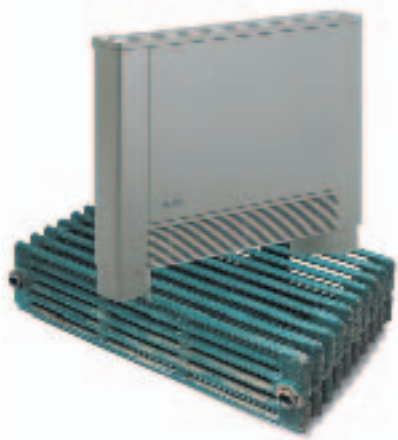

STANDS UP TO ANY COMPARISON

OUTPERFORMS CONVENTIONAL FAN COILS

- Fitted with radiating system.
- Eliminates noise in heating mode.
- Super-slim (about half the depth of most other models on the market).
- Allows for very accurate temperature settings.

OUTPERFORMS CONVENTIONAL HEATERS

- Reaches required temperatures in less time.
- Cools and dehumidifies in summer.
- No yellowing over time.
- Easily cleaned.
- Allows for very accurate temperature settings.

OUTPERFORMS FLOOR MOUNTED SYSTEMS

- Cools and dehumidifies.
- Consumes less because it is more efficient.
- Reaches required temperatures in less time.
- Fast, flexible installation.

NATURAL WARMTH AND COOLNESS

Optimum comfort comes from being cooled by ventilation, as if being cooled by a spring breeze. And from being warmed by radiation, as if being warmed by the sun. The Bi2 terminal unit, for the first time, combines both these natural elements.

Cool air produced by ventilation. The Bi2 is super-silent and does not create draughts. The unit provides increased cool air circulation.

VENTILATED COOLING

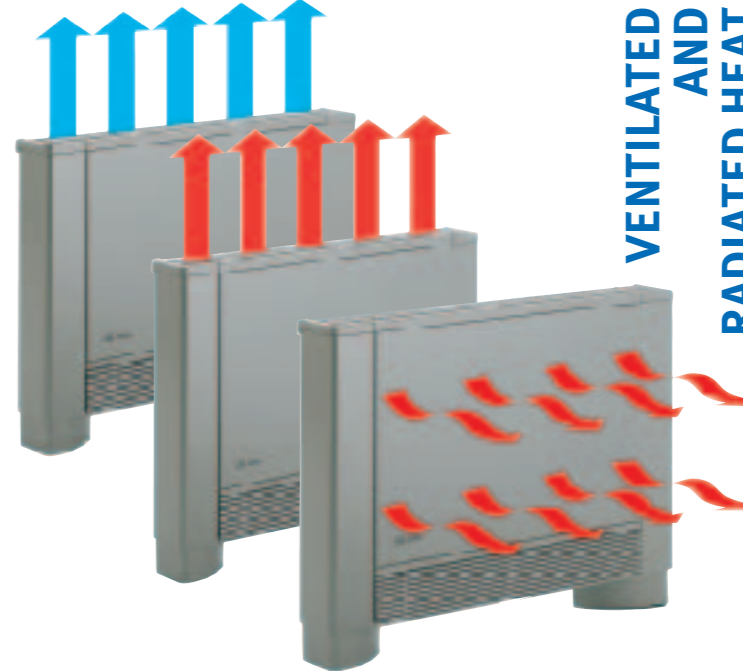

VENTILATED AND RADIATED HEAT

When first switched on, the Bi2 (SLR version only) starts heating by ventilation. This means that it very quickly reaches the desired temperature. Once the temperature has stabilised, the fan stops and the Bi2 continues to heat by convection by means of the radiator plate. As well as having high thermal inertia, the Bi2 accurately controls the temperature by means of an advanced electronic system available as an accessory kit.

The radiated heat of Bi2 and the reduced use of ventilation prevents the circulation of dust in the air. The Bi2 represents the ideal solution to household climate control.

NO MORE DUST

SMALLER SIZE HIGHER PERFORMANCE

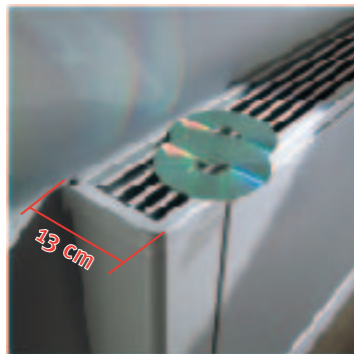

ULTRA SLIM Less than 13 centimetres deep: remarkable compactness that allows the Bi2 to fit perfectly into any setting.



EASY TO USE The Bi2 is the only unit that can be wall-mounted like the indoor unit of a "wall split" air conditioner. All you need is the drilling template and the adjustable supports (supplied). This makes mounting and, should it be necessary, dismantling, very straightforward. The optional feet also allow for floor mounting.



DESIGN Sober lines for a terminal unit designed to give long service both at home and in the office. The soft shape with no sharp corners makes the Bi2 ideal for any setting including rooms for children and the elderly. Design by Dario Tanfoglio.

ELECTRONICS The Bi2 can be controlled by a highly developed electronic system (optional) that assures the maximum precision in temperature control (PID logic) as well as flexibility of use and reduced power consumption.

OUTPERFORMS TRADITIONAL HEATING SYSTEMS

THE SECRET LIES DEEP INSIDE In heating mode, the special **Calostat valve** fitted on the SLR version of the Bi2, allows water to circulate through both the heat exchanger coil and the radiator plate. In cooling mode, the same valve prevents the passage of cold water (temperatures of less than 15°C) to the radiator plate, allowing it to flow into the coil only.

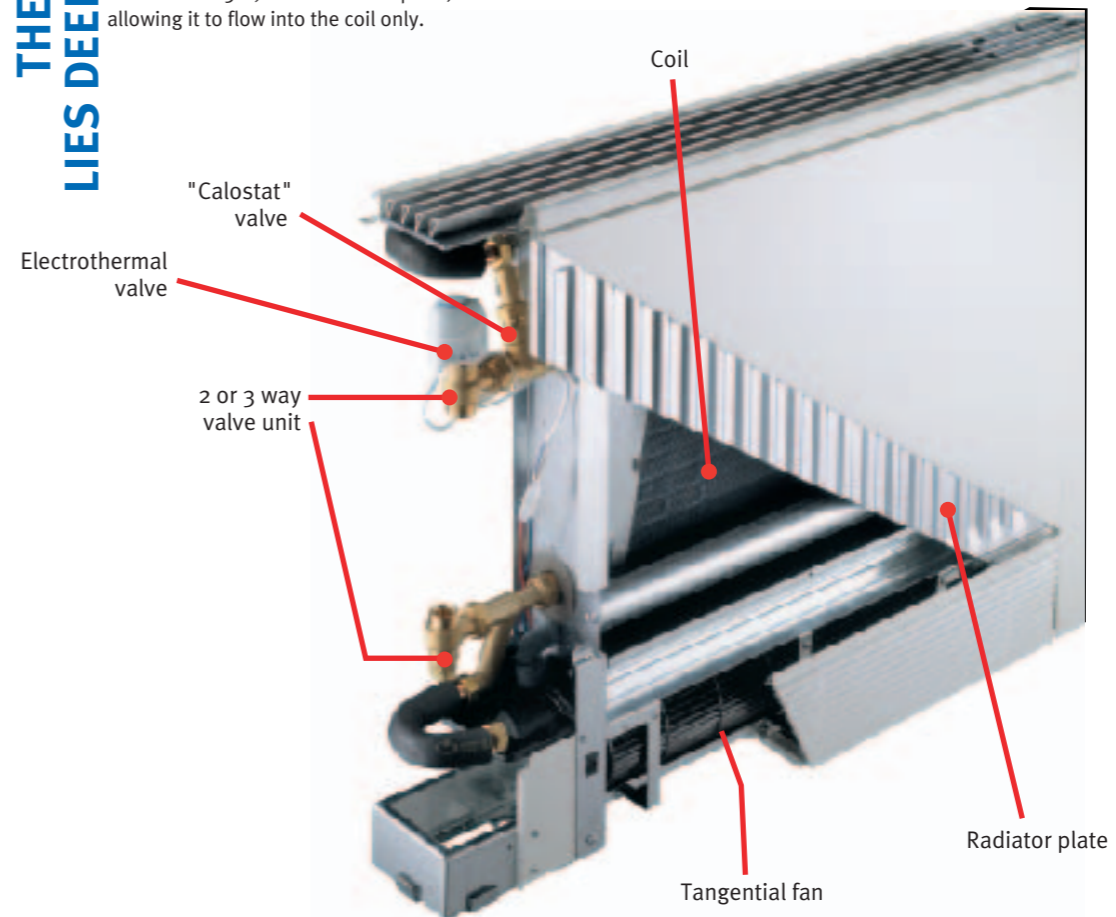



BUILT-IN VERSIONS
 Biz is also available in a range of five different power ratings, which can be flush-mounted without radiator plate (SLI versions). An extra way of enjoying the wellbeing that comes from ventilation.

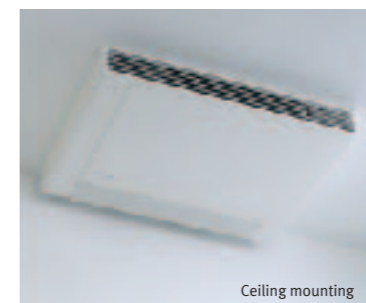

The Biz can be floor mounted, mounted on feet (accessories), wall mounted or ceiling mounted.

CAN BE FITTED IN VARIOUS POSITIONS



USER FRIENDLY TECHNOLOGY

The **two-way valve kit** (optional), complete with lockshield valve with flow control and the **three-way valve kit** (optional), complete with lockshield valve with flow control and bypass, ensure optimum balance of the system. Both kits are equipped with an electrothermal valve governed by the Biz control system or by external controls, if envisaged.

THE VALVE UNIT



In winter use, the required temperature is quickly reached thanks to **ventilation**; subsequently the radiator plate, by means of **convection**, keeps room temperature constant, thus assuring remarkable energy savings and complete silence.

ENERGY SAVING

A COMPLETE RANGE
 The Biz system of terminal units is truly complete. In all, 3 versions, 5 different power ratings and 25 models. 10 two-tone models with radiator plate, 10 two-tone models without radiator plate (fan coil type) and 5 flush-mounted models. Available colours: White (RAL 9010) and Silver (Metallic silver grey).



FILTER CLEANING

is simple and easy. An indicator light tells you when the air filters need to be cleaned. All you have to do is remove them and clean them with a vacuum cleaner or wash them in cold water.



CLEANING THE FAN

The tangential fan, (unlike many other fan coils) is positioned low down in the unit and is easy to reach. The fan can be cleaned by using a normal vacuum cleaner.